

Excellence in seaming

by PFAFF  
**Made**  
in Germany



**3588**

Programmable automatic pocket setter

# PFAFF 3588

## Efficient automatic pocket setter

Freely programmable automatic sewing unit for sewing pockets on jeans, shirts, blouses, work-wear and similar articles.

Pockets are not only functional, but also an important part of fashion, since they are very prominent on garments perfect workmanship is imperative. This is especially true, when functionality is combined with decoration.



### PFAFF 3588-12/021 and PFAFF 3588-22/021

- For shirts, blouses and similar articles
- For attaching un-folded pockets
- Sewing areas (mm):
  - subclass -12/021: 250 x 250
  - subclass -22/021: 280 x 280



### PFAFF 3588-05/020 and PFAFF 3588-15/020

- For Jeans, working wear and similar articles
- For processing pre-folded and un-folded pockets (in combination)
- Sewing areas (mm):
  - subclass -05/020: 250 x 250
  - subclass -15/020: 280 x 280

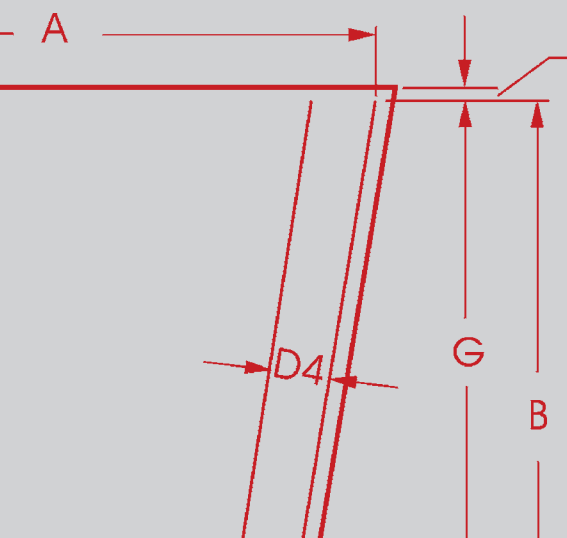

Symmetrical pockets:

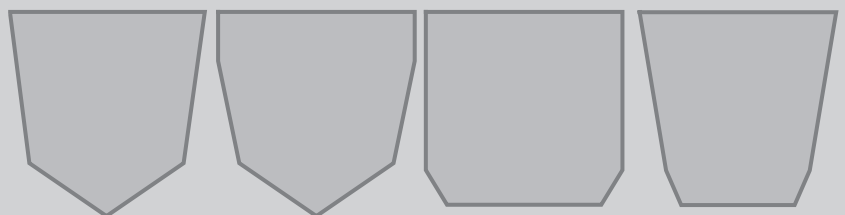

*„Best possible ergonomics,  
highest productivity and exceptional operating  
comfort characterizes this automated machine“*

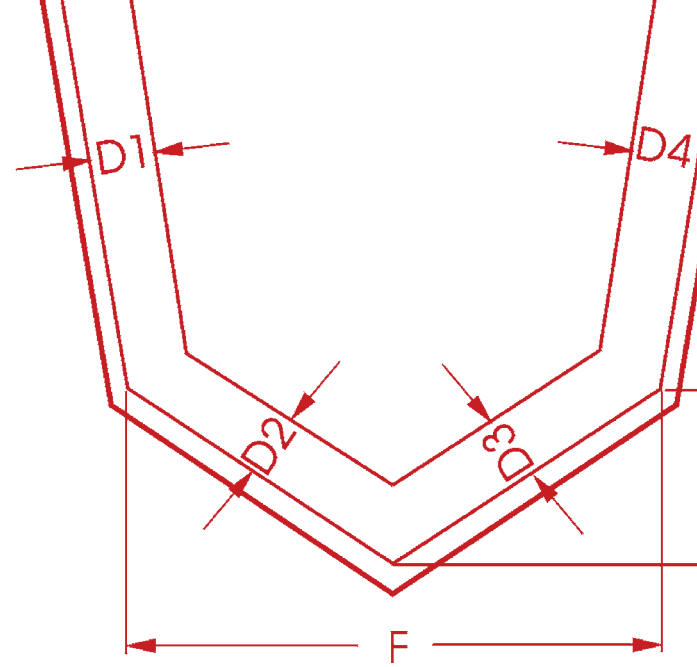

### Features and advantages:

- Efficient combination of two operations with optional style kits to set pockets and attach flaps in one operation or insert labels
- Superior sewing results even if setting pockets with radii < 20 mm
- Individually designing and programming of decorative seams
- Easy loading and positioning of work piece due to a 15 degree tilted work surface (ergonomic + comfortable)
- The intermittent material feed reduces hook wear to a minimum and allows stitch lengths of 6 mm (8 mm with optional software update)
- Individual seam programming and exact seam correction for different materials guarantee a highly sewing reliability and constant quality
- Rapid replacement of style kits: A fixed "zero point" makes it possible to use different style kits without time consuming re-adjustments
- Special PFAFF sewing head for automatic units with tilt sewing head
- High productivity, due to constant maximum sewing speed (4,000 s.p.m.) without speed reduction in corners or on bar-tacks
- Optional machine height adjustment activated on the touch screen control panel P1
- Touch control panel P1 (with SD card reader) displays all machine parameters in easily understandable symbols
- Optional small parts stacker

Asymmetrical pockets:

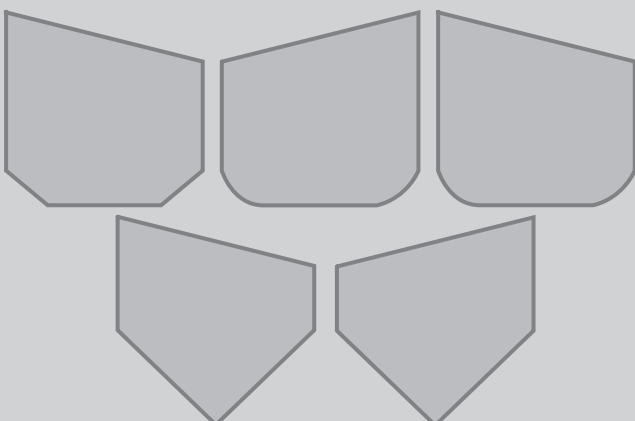

Bell-shaped pockets:



Examples of several pocket forms !

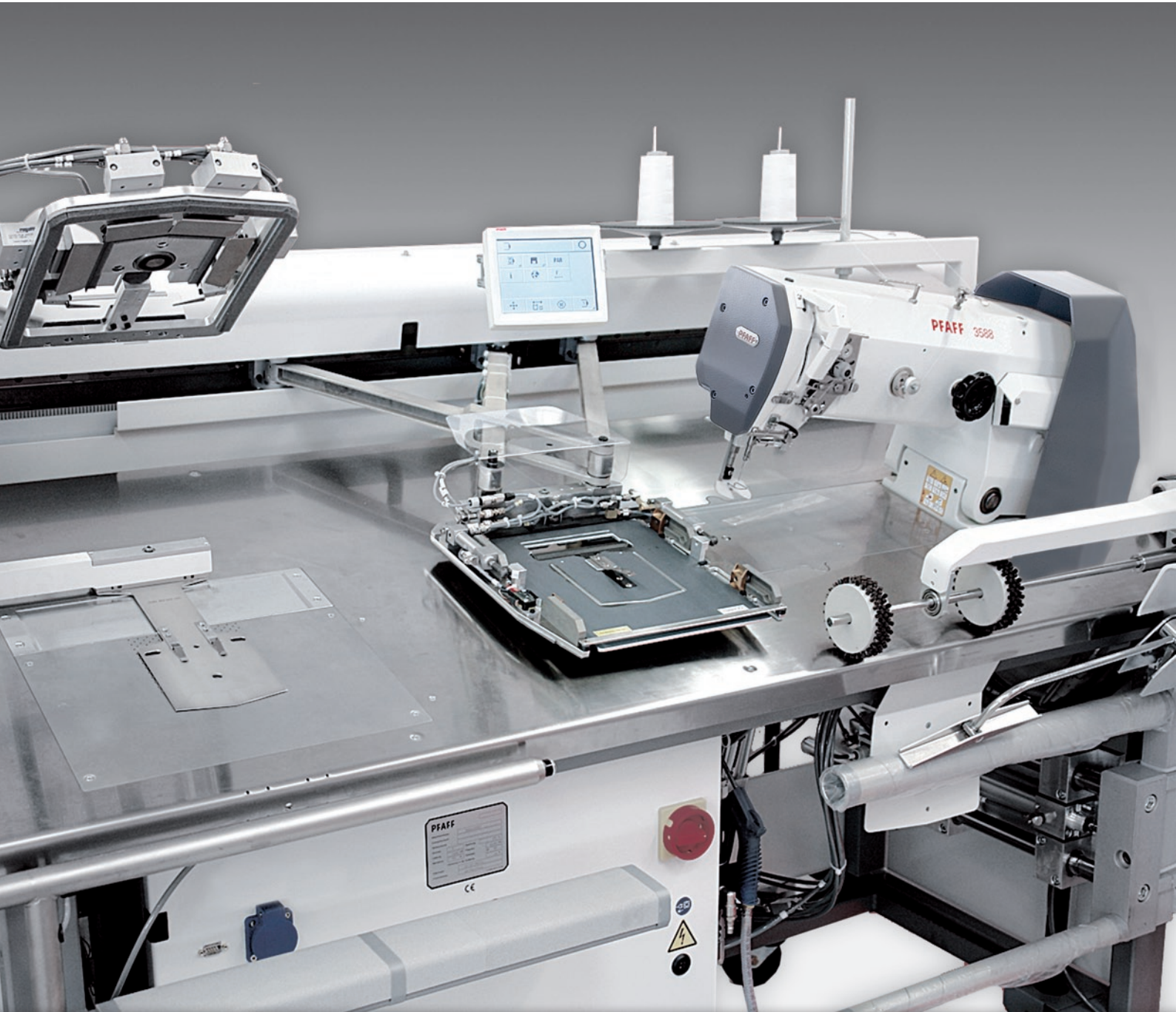

### Output data:

Cycle time for one standard shirt pocket

8 sec. = effective output of 2,600 pockets / 8 hours  
(plain fabrics)



Samples of different bartack designs !

# PFAFF 3588-12/021

The shirt pocket setter for all occasions

The classical solution for standard shirt pockets

PFAFF 3588-12/021 with pocket style kit no. 95-300 250-70:



## Further applications

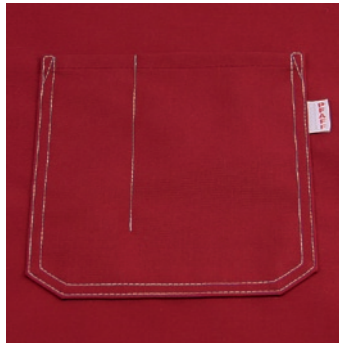

Pocket with label



Dress shield on sweatshirt materials

## Shirt pocket with flap

PFAFF 3588-12/021 with basic kit no. 95-776 422-90  
and pocket style kit no. 95-300 256-70:

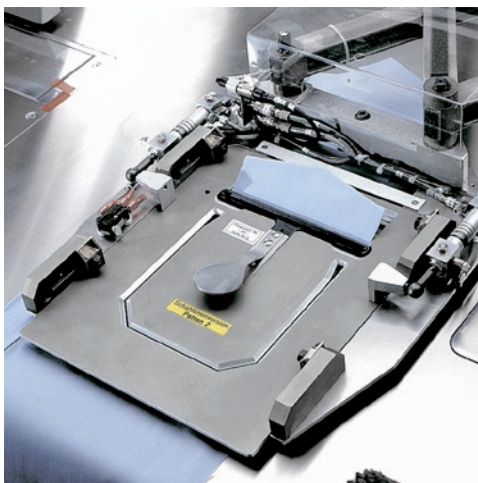

Shirt pocket with standard flap



Flap + additional seam for pen slot

Sewing on ready made flap:  
no. 95-300 310-70

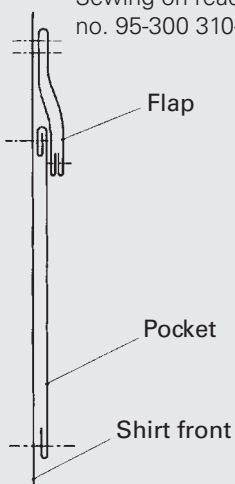

Sewing on and top-stitching flap:  
no. 95-300 311-70

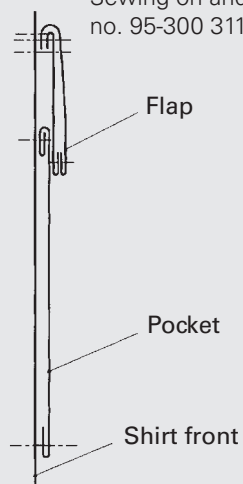

Easy positioning even  
when working with  
stripes or plaids

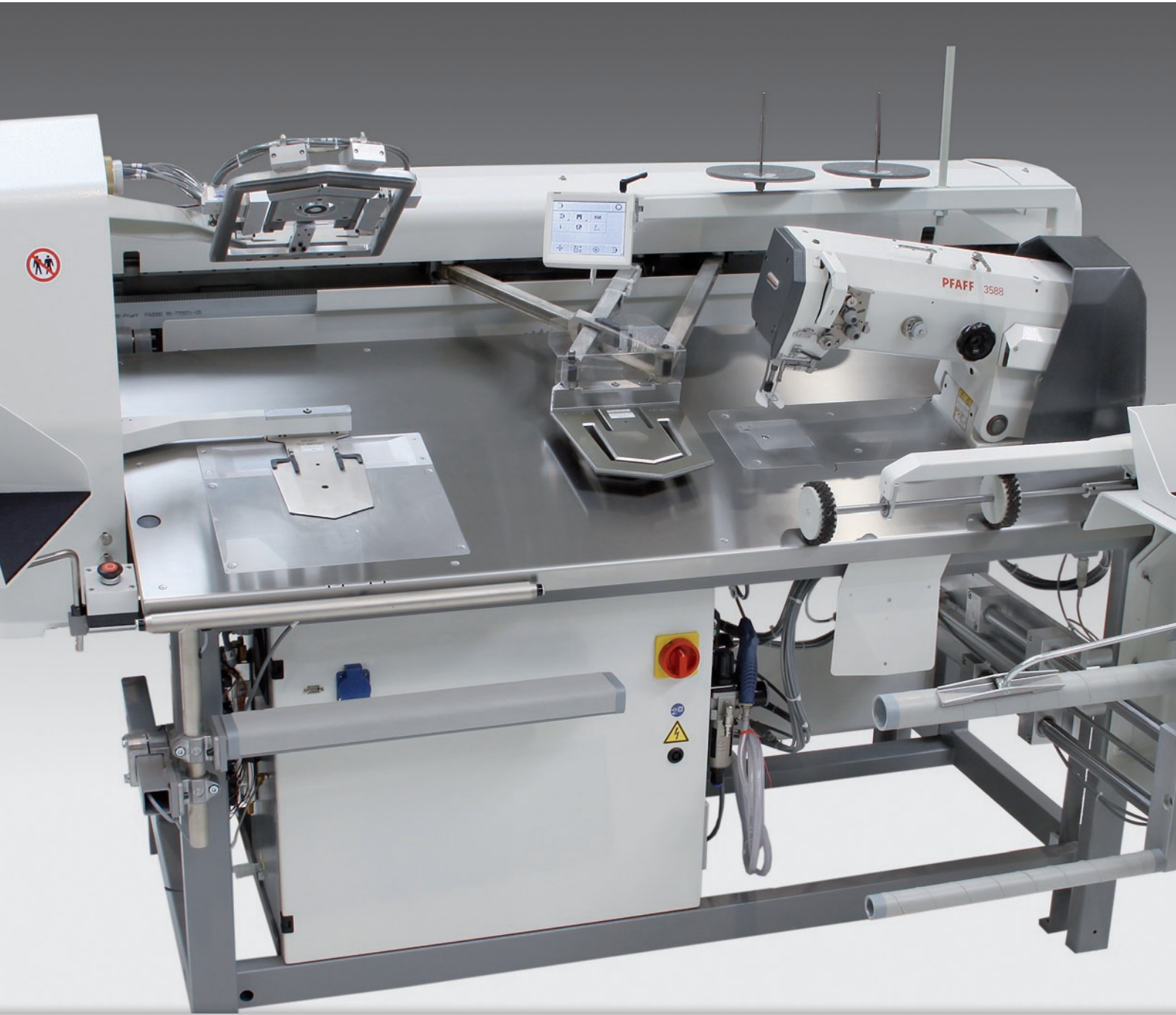

Output data:

Cycle time for one standard jeans pocket:

9 sec.= effective output of 2,400 pockets / 8 hours

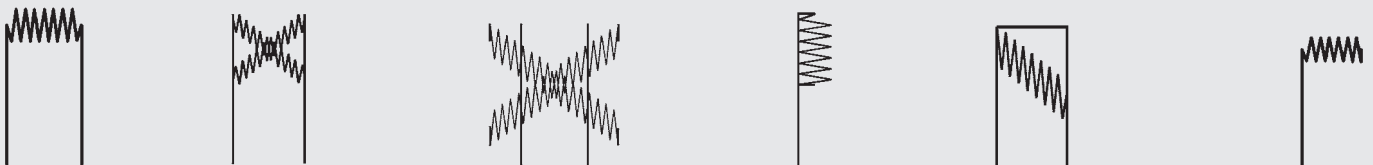

Samples of different bartack designs !

# PFAFF 3588-05/020 and PFAFF 3588-15/020:

The Jeans pocket setter - The economical answer in every situation

## The classic solution for standard jeans pockets

PFAFF 3588-05/020 or 3588-15/020 in combination with pocket style kit no. 95-300 250-70 with integrated folding unit

In operation as a combination machine:

- Processing of **pre-folded** and **unfolded** pockets
- Sewing of cotton and synthetic threads up to thread sizes 11/3
- Multi-size style kit for multiples sizes

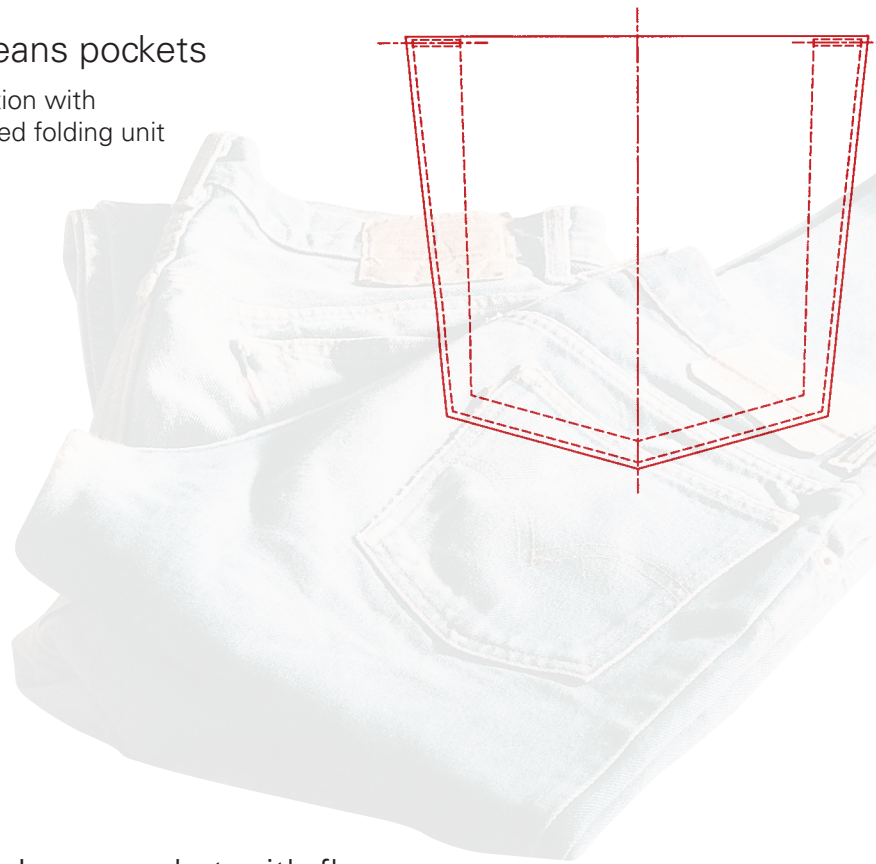
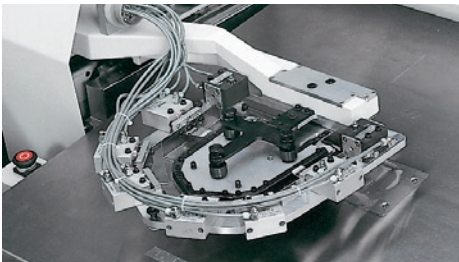

## Jeans pocket with flap

PFAFF 3588-05/020 with basic kit no. 95-776 422-90 and pocket style kit no. 95-300 256-70 (Jeans, work wear and similar products)

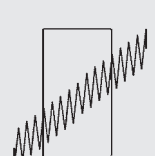
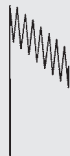
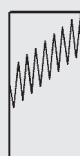
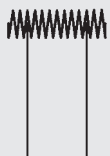
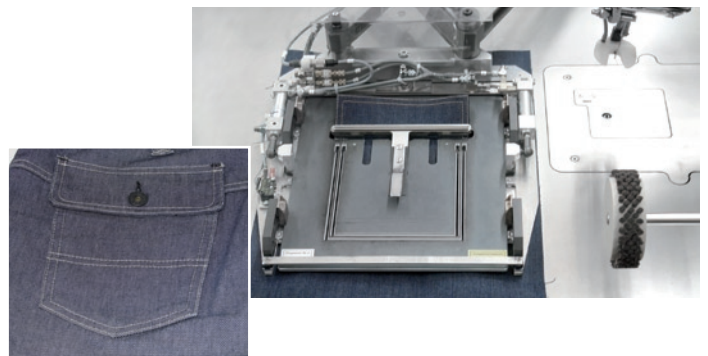



Example: Cargo pocket "L-Shape"

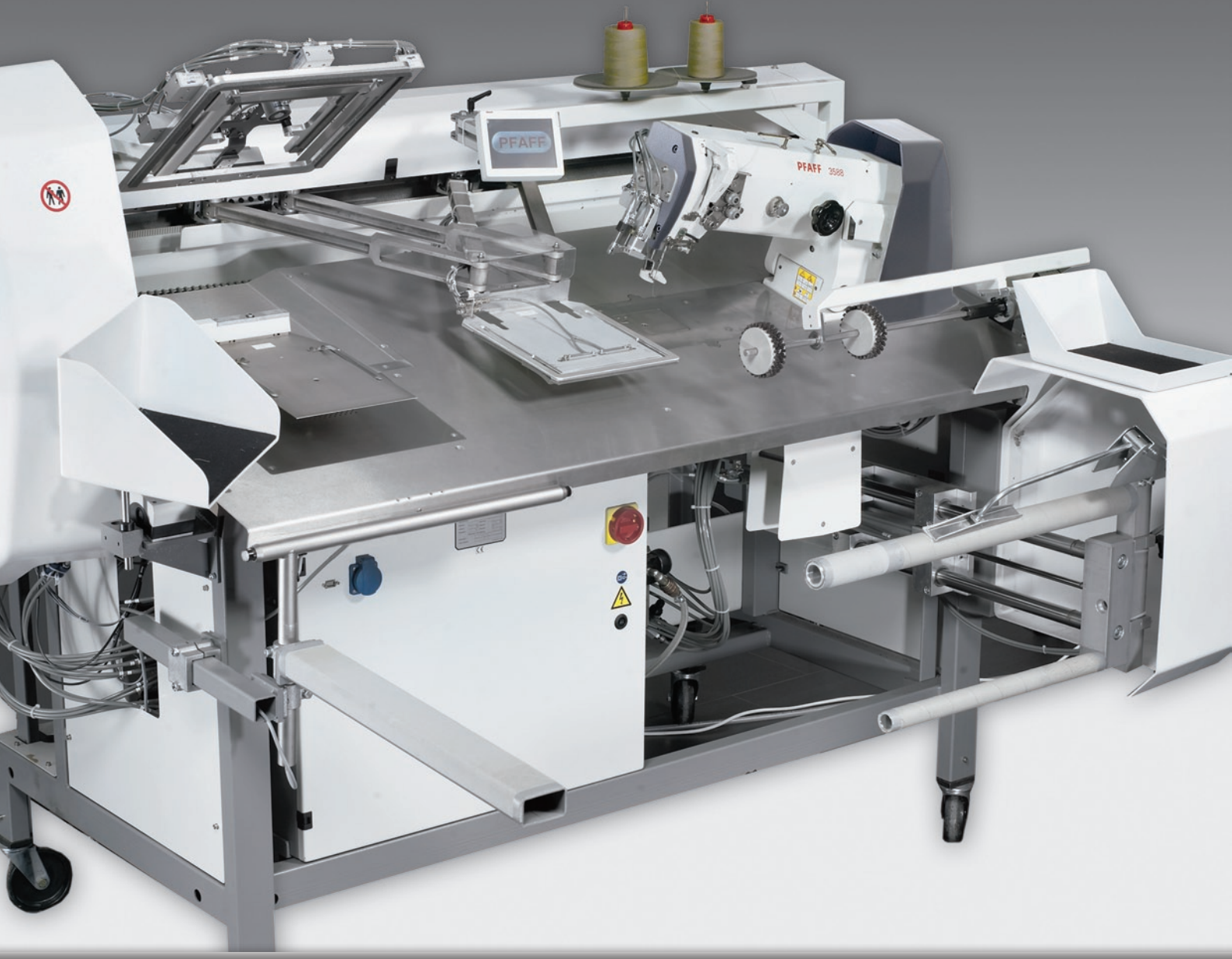

### Cargo - one sided

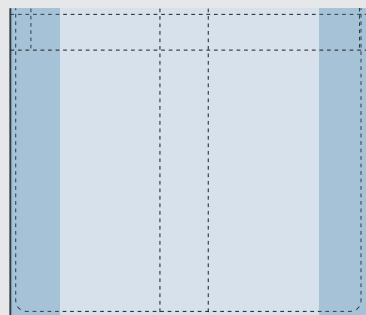
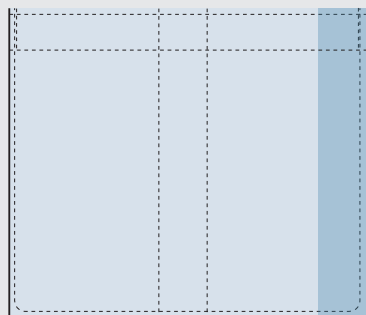
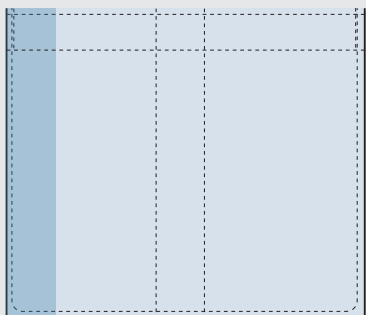

# PFAFF 3588 Cargo

Efficient attaching of side pockets

Efficient production of cargo- and bellows pockets  
(work wear, sports wear and military garments)

## Cargo - one sided: \*

with basic kit no. 95-778 494-70/893  
and pocket style kit no. 95-300 300-70

Version for pleats on left and/or right side

## Cargo - L-Shape: \*

with basic kit no. 95-778 466-70/893  
and pocket style kit no. 95-300 300-70

Version for pleats on the left OR right  
side and bottom of pocket

\* basic machine: PFAFF 3588-05/020 or PFAFF 3588-15/020

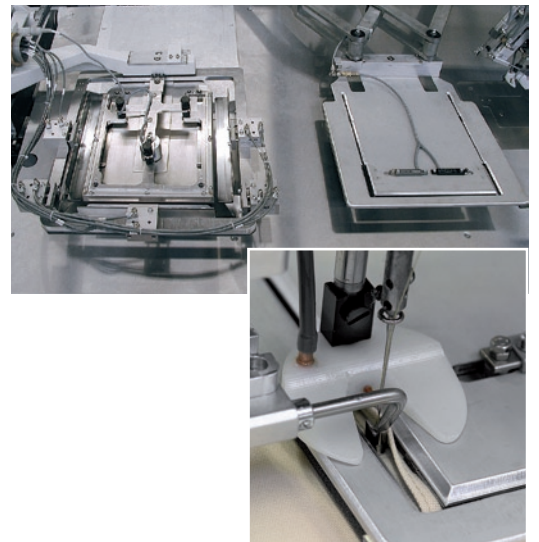

## Bellows pockets:

with machine PFAFF 3588 Cargo Plus

Efficient attaching of bellows pockets.  
The degree of automation is unique  
to the PFAFF 3588 Cargo Plus

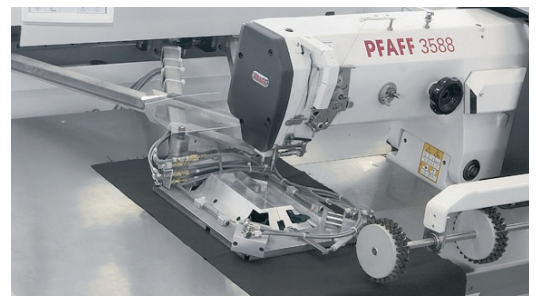

Sewing area 180 x 210 mm  
further sewing areas on request

## Cargo - L-shape

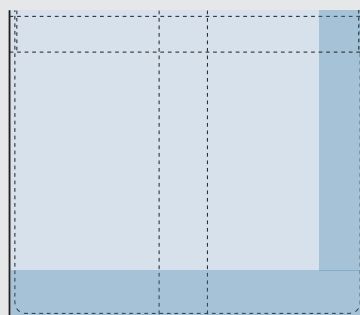
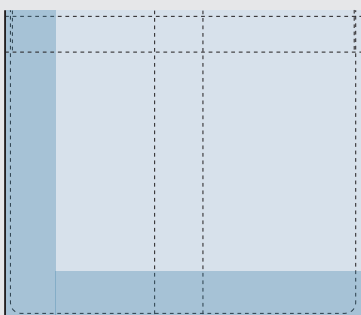

## Bellows pocket

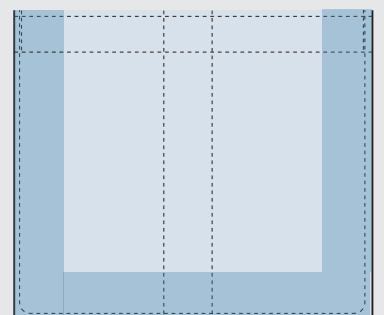







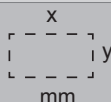

## Versions and style kits:

PFAFF 3588-12/021 *		SHIRT -12/021	
PFAFF 3588-22/021 *		SHIRT -22/021	
PFAFF 3588-05/020 *			JEANS -05/020
PFAFF 3588-15/020 *			JEANS -15/020
PFAFF Cargo Plus for bellows pockets (on request)			
<b>PARTS-KIT FOR STANDARD POCKETS</b>			
95-300 250-70	Pocket style kit for un-folded pockets (Folder, pocket plate, sewing jig)	●	●
<b>PARTS-KIT FOR POCKETS WITH FLAPS</b>			
95-300 256-70	Pocket style kit for flaps (Folder + pocket plate)	●	●
95-776 422-90	Basic kit for attaching pockets with flaps (Max. pocket size: L: 200 mm, W: 180 mm)		
95-300 310-70	Sewing jig for attaching finished flaps	●	●
95-300 311-70	Sewing jig for attaching and top-stitching of open flaps	●	●
<b>PARTS-KIT FOR CARGO POCKETS (without flaps)</b>			
95-300 300-70	Pocket style kit for cargo pockets		●
95-778 494-70/893	Basic kit for cargo pockets – one sided (Version for pleats on left and/or right side)		●
95-778 466-70/893	Basic kit for cargo pockets – L-shape (Version for pleats on the transverse side and longitudinal side - left or right)		●
<b>PARTS-KIT FOR PRE-FOLDED POCKETS</b>			
95-300 308-70	Pocket style kit for pre-folded pockets		●
95-776 633-90	Basic kit for pre-folded pockets		
95-776 535-70/895	Set of blanks for in-house production of pocket style kit		●
<b>PARTS-KIT "MULTI SIZE"</b>			
95-300 313-70	for un-folded pockets without flap (variable folder, pocket plate and jigs for the pocket shape / -size)	●	●
95-300 314-70	Parts-kit for one more pocket size		



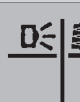



\* Each machine has to be equipped with one pocket style kit

## Technical data + specifications:

Types								
	Sewing area	Number of threads	Vertical hook, large	Horizontal hook, small	Needle positioning	Thread trimmer	Bobbin thread monitor	Presser foot lift
<b>-12/021</b> / Shirt	250x250	●		●	●	●	●	●
<b>-22/021</b> / Shirt	280x280	●		●	●	●	●	●
<b>-05/020</b> / Jeans	250x250	●	●		●	●	●	●
<b>-15/020</b> / Jeans	280x280	●	●		●	●	●	●
<b>Cargo plus</b>	180x210	●	●		●	●	●	●

## Optional equipment:

PFAFF 3588-12/021		HEMD -12/021	
PFAFF 3588-22/021		HEMD -22/021	
PFAFF 3588-05/020			JEANS -05/020
PFAFF 3588-15/020			JEANS -15/020
PFAFF Cargo Plus for bellows pockets (on request)			
95-775 577-70/893	Sewing head tilting mechanism for easy bobbin change	●	
VARIABLE SEWING SLOT - recommended for a double seam in light fabrics (shirts) and seam depths < 2,4 mm (jeans)			
95-776422-90	Basic kit	●	●
95-300 255-70	Sewing jig with variable sewing slot		
DEVICE FOR PROCESSING LABELS and BELL-SHAPED POCKETS			
95-776 566-90	Basic kit for labels and bell-shaped pockets	●	●
95-300 315-70	Label positioning device - left pocket side	●	●
95-300 316-70	Label positioning device - right pocket side	●	●
95-300 307-70	Pocket plate (splitted) for bell-shaped pockets		●
DEVICE FOR JIG MONITORING (if required each pocket style kit needs to be equipped)			
95-776 519-90	Sewing jig monitoring	●	●
91-291 930-90	Basic kit		
91-291 919-91	SOLENOID - to support the folding process	●	●
91-291 920-90	Basic kit (magnet)		
95-775 883-70/893	Height-adjusting device (motor driven)	●	●
95-775 715-90	Feed rollers (4 pieces)	●	●
95-778 238-90	Stacker for short parts	●	●

Types		SD-Card	 max	 - System	 mm		 - Nm
	Large part stacker	Data storage	Stitches per minute, max.	Needle system	Stitch length, max.	Needle cooling	Needle size
<b>-12/021</b> / Shirt	●	●	4.000	134	5	●	70-110
<b>-22/021</b> / Shirt	●	●	3.600	134	5	●	70-110
<b>-05/020</b> / Jeans	●	●	4.000	134 MR	5	●	110-160
<b>-15/020</b> / Jeans	●	●	3.600	134-35 SERV7	5	●	110-160
<b>Cargo plus</b>	●	●	2.000	134	5	●	100-140

## Technical Data:

**Stitch type**

301 (lockstitch)

**Connection voltage:**

230 V single-phase a.c.  
50/60 Hz

**Working pressure:**

6 bar

**Air consumption:**

approx. 25 l/cycle

**Net weight:**

approx. 650 kg

**Dimensions (mm):**

Length: approx. 2.250

Breadth: approx. 1.150

Height: approx. 1.450

Height of front : 870 to 1.170  
edge of table

Hotline:

Technical Service: +49-175/2243-101

**PFAFF Industriesysteme  
und Maschinen AG**

Hans-Geiger-Str. 12 – IG Nord  
D-67661 Kaiserslautern

Telefon: +49-6301/3205-0

Telefax: +49-6301/3205-3171

E-mail: [info@pfaff-industrial.com](mailto:info@pfaff-industrial.com)

Printed in Germany  
engl.  
296-12-18228 08/11